



## **Technical Data Sheet Swing Door Operator – Besam SW100**

### **The most versatile and reliable operator**

The Besam SW100 is especially designed for low-energy applications with high intelligent functions to support safety and comfort for most types of pedestrian doors.

The operator can be mounted on either side of the door for pull or push action and is suitable for single- or double-doors fitted with butt hinges or pivots.

### **Silent and smart**

The Besam SW100 has been developed to comply with European standards and requirements for low-energy power-operated doors.

The smart control unit offers added-value features like power assist, smart double-door controls and monitored battery back-up for convenience. Other added-value features are smart lock functions for security, monitored sensors and low-energy consumption.

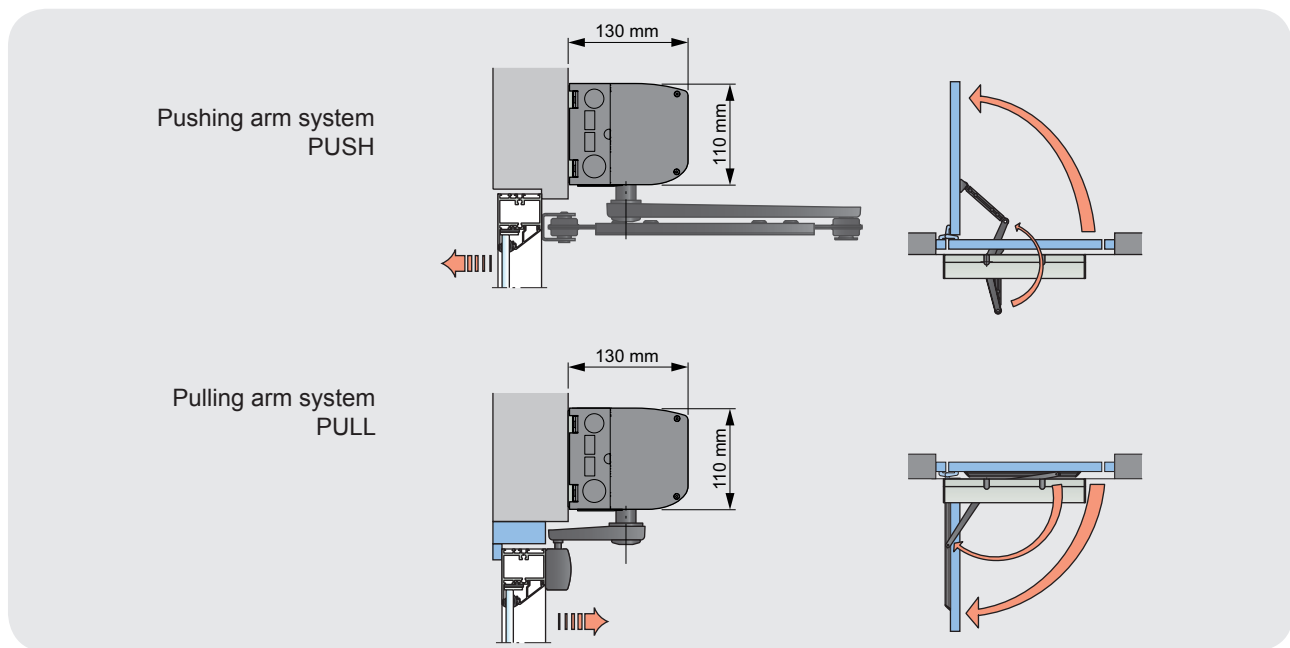

### Models

- Single operator – one drive unit and one control unit fitted under a cover
- Double operator – two drive units with control units fitted under the same cover for operation of two doors

### Arm systems

- Pushing arm system PUSH – The operator is installed on the wall on the opposite side of the door swing. Door opening angle adjustable up to 110°
- Pulling arm system PULL – The operator is installed on the wall on the same side as the door swing. Door opening angle adjustable up to 110°
- Pulling arm system ST-V/H – Used in windy conditions when the operator is installed on the wall on the same side as the door swing. Door opening angle adjustable up to 90°
- Drive shaft extensions – Allow the operator to be fitted higher on the wall or the arm lower on the door leaf

### Standard equipment

- Cover – manufactured in clear anodized aluminium. End plates made of black painted steel sheet
  - Dimensions: Height 110 mm
  - Depth 130 mm
  - Single operator: Length 716 mm
  - Special length covers up to 1600 mm
  - Double operator: Length optional
- Control unit CU-ESD – with possibility to connect manual and automatic activation units, position switches and overhead presence detectors (OPD)
- “Push and go” – the door opens automatically from closed position if manually pushed
- Power assist – the motor gives power assist when the door is opened by hand

### Accessories and Options

- Extension unit EXU-SI – Used if additional functions are required, e.g. electro-mechanical lock, program selector, emergency battery, kill function open/close, key opening and outer impulse
- Extension unit EXU-SA – Has inputs for both monitored /non monitored door mounted sensors, which can give presence impulse and/or presence detection. Relay output for error or door indication is also integrated.
- Sync cable – Used on double doors to select the opening and closing order
- Finger trap protection devices
- Manual and automatic activation units
- Impulse and presence detection sensors
- Programme selectors
- Monitored battery backup unit: 24 VDC 1200 mA
- Electro-mechanical locking connection: 12 VDC max 500 mA or 24 VDC max 250 mA

### Technical specifications

- Power supply: 100-240 V AC, +10/-15%, 50/60 Hz
- Power consumption: max. 75 W
- Auxiliary voltage: 24 V DC, max. 400 mA
- Internal control fuse: 2 x T 6.3 AH 250 V
- Door leaf width: max. 1200 mm
- Recommended door weight: max. 90 kg
- Door opening angle: 80 - 110°
- Reveal: Push 0 - 100 mm (300 mm with longer telescopic part) / Pull 0 - 130 mm
- Opening and closing time: variable between 3 - 6 sec.
- Hold open time: 1.5 - 30 sec.
- Ambient temperature: -20°C to +45°C
- Relative humidity (non-condensing) max 85%
- Class of protection: IP20 - to be installed internally or externally with suitable weather protection
- The SW100 complies with the UL 325 ANSI / BHMA A156.19, BS7036:1996 part 4 and DIN 18650 requirements for low-energy power-operated doors

This equipment should be installed, regularly inspected, maintained and serviced by trained and authorized personnel. Preventive maintenance plans are highly recommended for a proper and safe operation. Talk to your Besam representative!

Besam Export AB, Box 669, SE-261 25 Landskrona, Sweden  
 Tel: +46 418 514 00 Fax: +46 418 513 55  
 export@besam.se • www.besam.com